



Installation of the *Classique 12V* Electronic ignition

The MCC electronic ignition, black cover, is made for the standard black coil and maybe use for the 6v or 12v coil.

- The installation :

Cut the contact, dismount the fan and the rubber waterproof seal of the ignition.

Remove the ignition case and its condenser, remove the intermediate metal plate.

Remove the joint of the distribution cam. Depose it, as well as the centrifugal weights. Conserve the 2 fixation screws M7. Clean well.

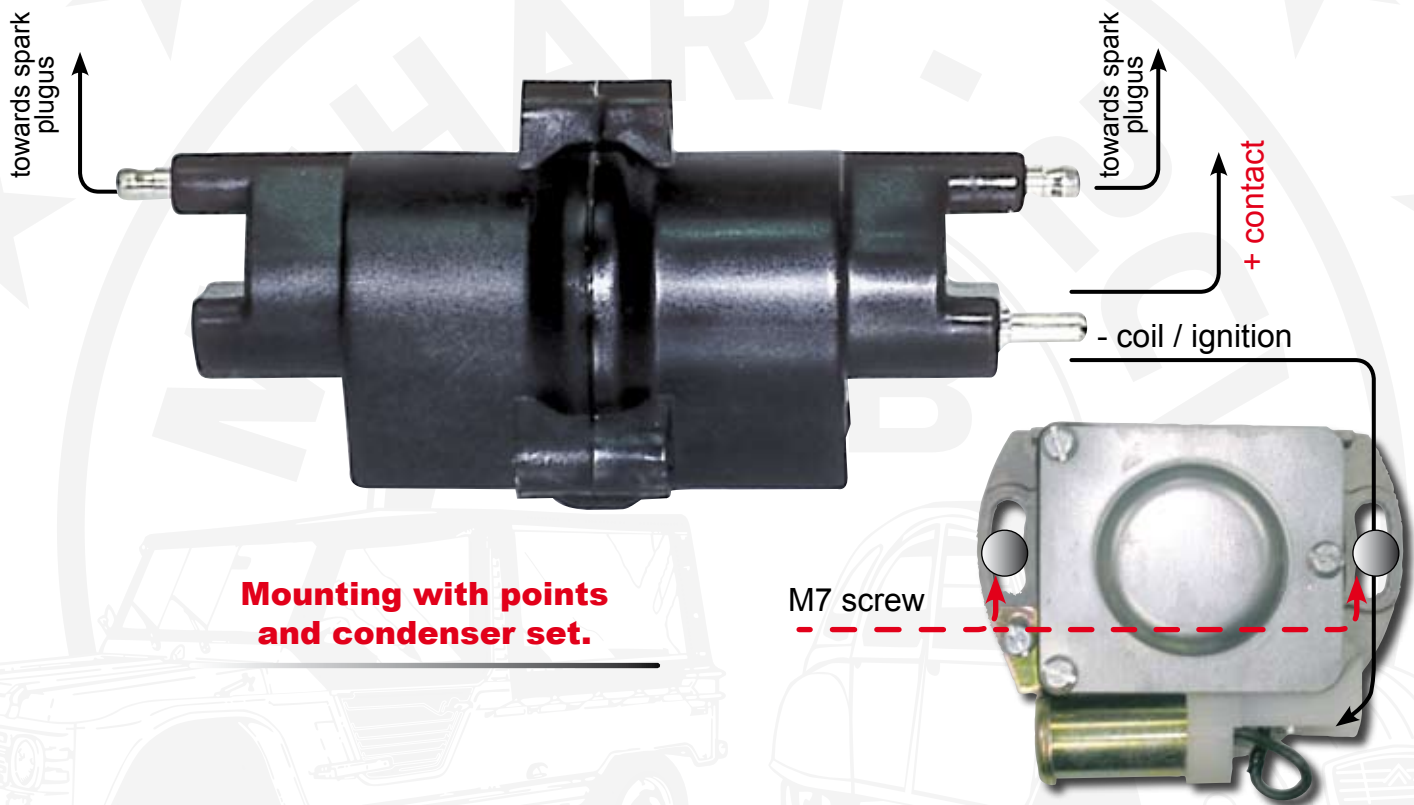

Place the 2 cylindrical magnets on the axes (old fixation of the centrifugal weights).Place the electronic case with the 2 screws M7 and the discs, do not block the screws this allows you to set timing.

cylindrical magnets

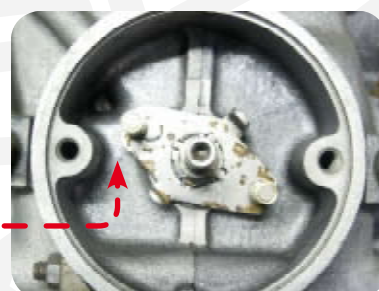

Installation **Standard 12V ignition**

Cable plan for the electronic ignition

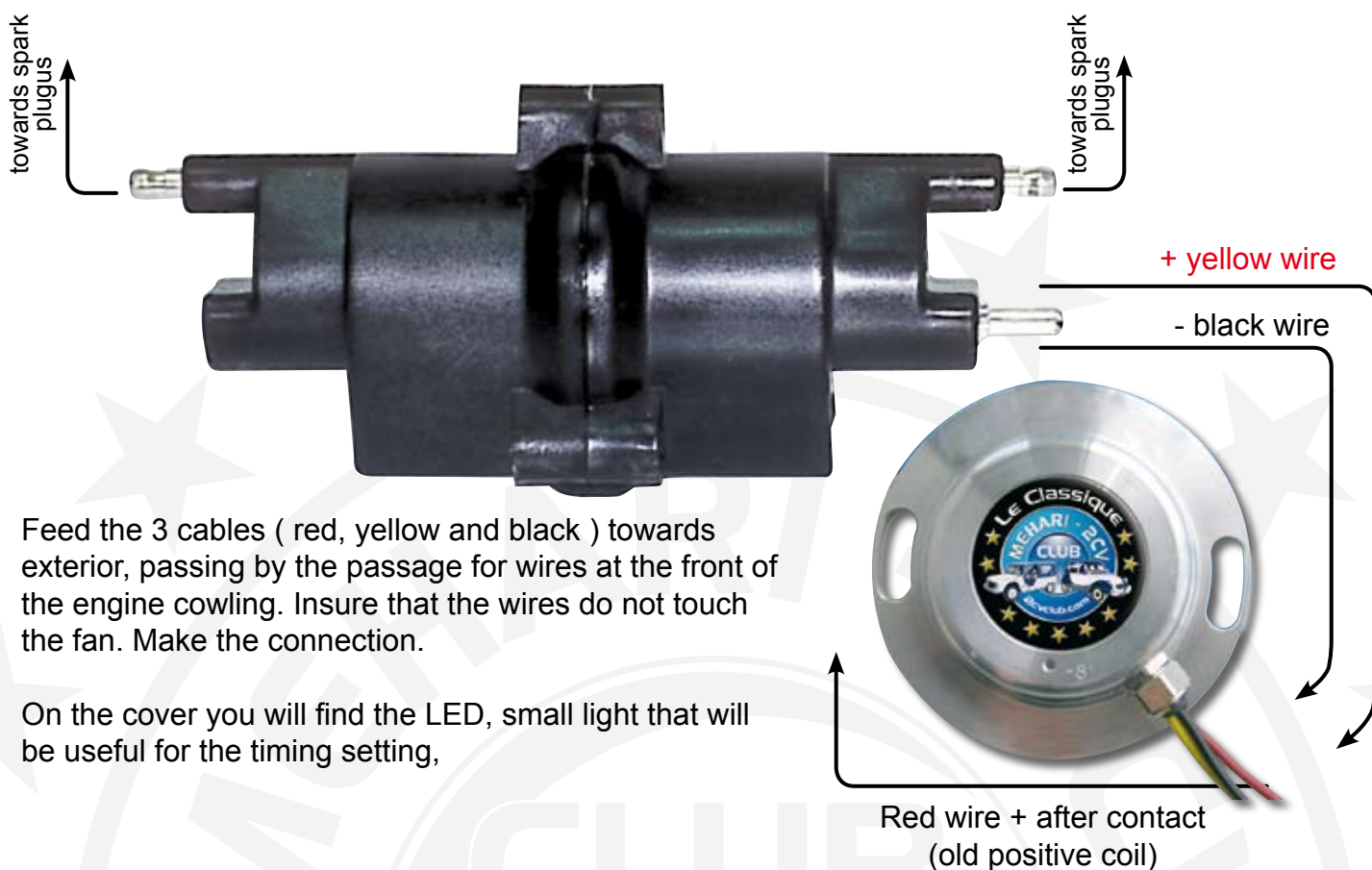

Feed the 3 cables (red, yellow and black) towards exterior, passing by the passage for wires at the front of the engine cowling. Insure that the wires do not touch the fan. Make the connection.

On the cover you will find the LED, small light that will be useful for the timing setting,

The timing setting

Screw the fanbolt into the crankshaft. Insert a 6 mm timing rod through the hole in the crankcase. Align the crankcase hole (under the left inlet pipe) with the flywheel hole (as anticipated by the constructeur).

Remove the timing rod (very important). Turn the contact, turn the electronic box to the left until the LED goes out, then turn the box towards the right. At a precise moment when the LED comes on. Tighten with 2 M7 screws.

Remount the fan, the fan cover etc...Connect the sparkplug leads....your installation is over....

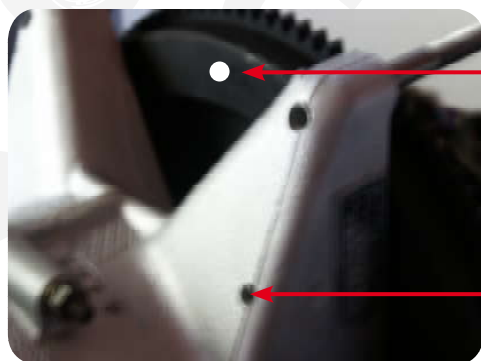

Flywheel hole

Crankcase hole